

## Agilent 87415A, 87400A Microwave Amplifiers

### Product Overview

#### 2 to 8 GHz

#### Features and Description

- 25 dB gain
- 23 dBm output power
- GaAs MMIC reliability >1 x 10<sup>6</sup> hours MTBF
- Compact size, integral bias regulation

The Agilent Technologies 87415A and 87400A microwave system amplifiers bring compact, reliable gain block performance to systems integrators and microwave designers. With 25 dB minimum

gain and over 23 dBm output power from 2 to 8 GHz, these amplifiers offer output power where it is needed: at the test port. Both amplifiers offer internal bias regulation and GaAs MMIC reliability, and the 87415A adds integral heat sinking, bias port cabling, and stand-alone packaging for use in test system applications. The 87400A offers similar performance in a compact microcircuit-only package for OEM amplifier applications.

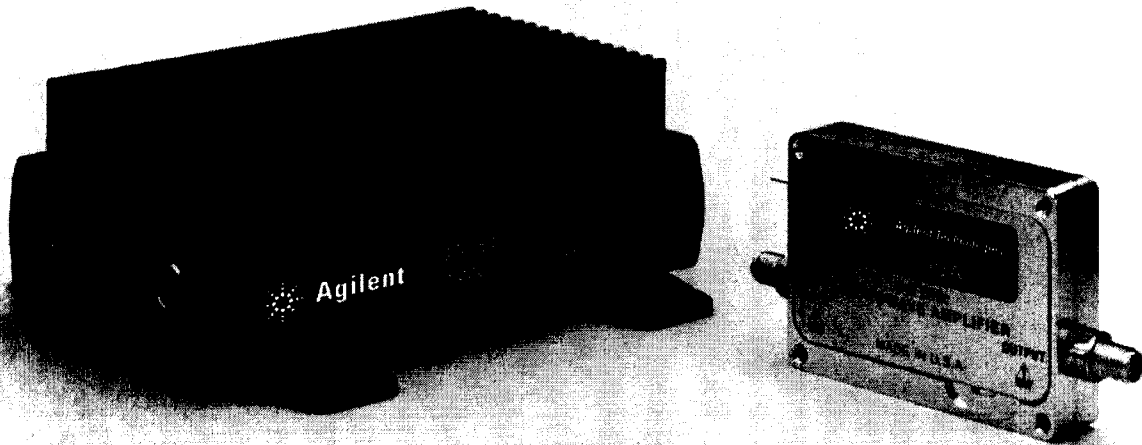

**Agilent Technologies**

Innovating the HP Way

## Packaging

These two gain blocks differ primarily in level of integration. Both amplifiers share similar internal GaAs MMIC devices, but the 87415A features a complete, stand-alone solution for test system designers and integrators. An integral heat sink keeps the package at a temperature comfortable to the touch, enhancing its use as a benchtop amplifier, and a DC bias port allows easy connection to an external power supply such as the 87421A.

Without the heat sink and base, the smaller 87400A easily fits tight OEM applications. To ensure optimum performance and product life, an external heat sink or forced air cooling is recommended for the 87400A to keep the case temperature below +55 °C.

## 87415A Microwave System Amplifier 87400A<sup>1</sup> Microwave Component Amplifier

### Specifications

**Specifications** describe the instrument's warranted performance over the temperature range 20 °C to 30 °C (unless otherwise noted). All specifications apply after the instrument's temperature has been stabilized after one hour continuous operation.

**Supplemental characteristics** are intended to provide information useful in applying the instrument by giving typical but nonwarranted performance parameters. These are denoted as "typical," "nominal," or "approximate." Supplemental characteristics apply over the temperature range 20 °C to +30 °C.

<b>Frequency Range</b>	2 to 8 GHz
<b>Small Signal Gain</b>	25 dB minimum
<b>Small Signal Gain Flatness</b>	± 3 dB maximum
<b>Output Power at 1 dB Compression Point</b>	23 dBm minimum
<b>Input SWR</b>	2:1
<b>Output SWR</b>	3.6, 2 to 2.5 GHz 3, 2.5 to 8 GHz
<b>Harmonics</b>	-20 dBc at Pout = +23 dBm

### General Specifications

<b>Power Requirements</b>	
<b>Bias Voltage and Current</b>	+12 V dc nominal (+11 to +13 V dc); 900mA
<b>Weight</b>	Net 0.64 kg (1.41 lb) Shipping 1.32 kg (2.9 lb)
<b>RF Connectors</b>	SMA (f) on RF input and output

1. Agilent 87400A microcircuit specifications and supplemental characteristics apply between 45 to 55 °C case temp.

## Applications

The 87415A's compact size makes it an ideal remote amplifier for use by microwave test system integrators. It is a complete, off-the-shelf gain block that enables the system designer to place system power where it is needed, without consuming valuable rack space. Typical applications include microwave test sets and interface matrixes.

## Loss compensation

Compensate for systematic power losses from switching and signal routing ATE systems, frequency conversion, and long microwave cable paths. Use the 87415A microwave system amplifier to recover lost signal strength at test cable ends.

## Level source output power at a remote test port

By combining the 87415A or 87400A amplifiers with an 87300B directional coupler and an 8471E coaxial microwave detector, as shown in Figure 1, levelled source power can be available at the test port.

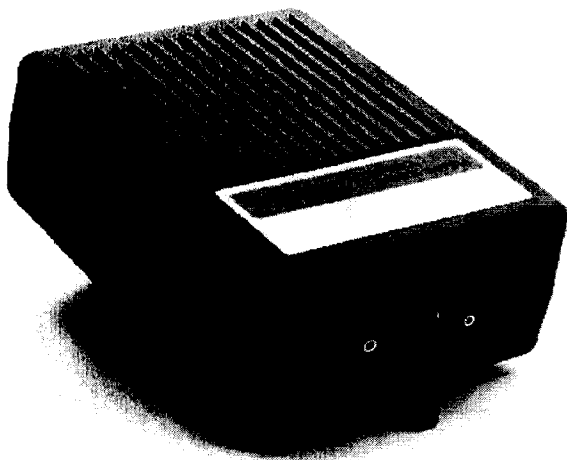

Agilent 87421A Power Supply

## Preamp

As a preamp, the 87415A can increase spectrum analyzer and frequency counter sensitivity.

## Benchtop amplifier for the RF and microwave designer

The 87415A microwave system amplifier gives the microwave engineer 30 dB gain and 23 dBm output power without consuming valuable bench or rack space. Other applications include antenna subsystems and production test systems. The 87400A OEM component amplifier offers the 87415's electrical performance in a small microcircuit package. Ideal for instrument applications needing small, internally biased gain blocks, this amplifier offers designers a very small, easy to integrate package, configuration flexibility, and GaAs MMIC reliability.

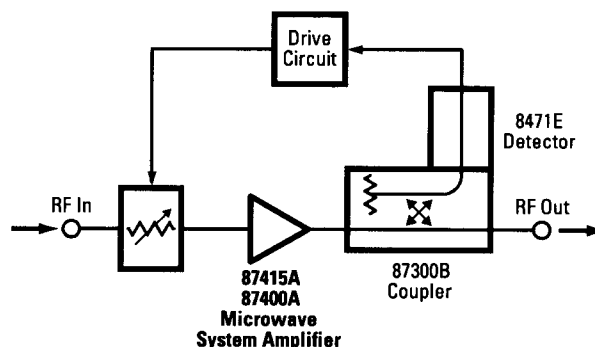

Figure 1. External leveling looping

**Separate Power Supply**

The Agilent 87421A power supply provides the dc power needed to bias the 87415A. The power supply is housed in a small separate package, allowing it to be placed up to two meters away from the amplifier.

**Electrostatic Discharge Caution**

Electrostatic discharge (ESD) can damage or destroy electronic components. It is recommended that these amplifiers, like other electronic components be installed and operated at a static-free workstation or in an environment where precautions against ESD have been implemented.

**SMA (f) connectors on all RF ports**

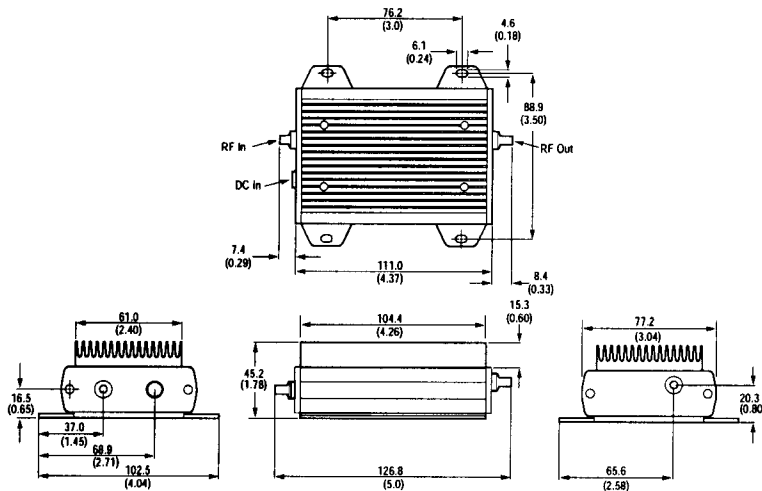

**Figure 2. Agilent 87415A outline drawing. Dimensions in millimeters and (inches).**

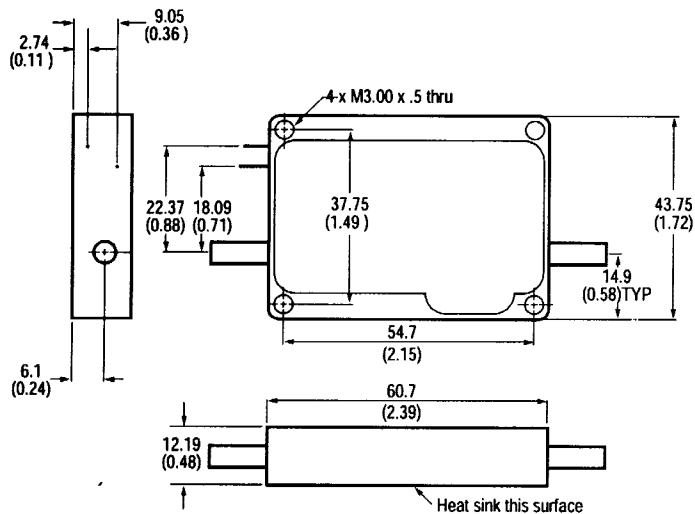

**Figure 3. Agilent 87400A outline drawing. Dimensions in millimeters and (inches).**

**Typical Performance Data**

<b>Saturated Power Level:</b>	+26 dBm
<b>Input Power Survival Level:</b>	+23 dBm
<b>Noise Figure:</b>	13 dB
<b>Non-Harmonically Related Spurious:</b>	-50 dBc
<b>Third Order Intercept (TOI):</b>	+34 dBm
<b>Impedance:</b>	50 ohms
<b>Reverse Isolation: (S<sub>12</sub>)</b>	60 dB
<b>Power Dissipation:</b>	10 W

**Environmental Specifications**

<b>Operating Temperature:</b>	0 to +55 °C
<b>Storage Temperature:</b>	-40 to +70 °C

**Other Environmental Information**

<b>Temperature Coefficient of Gain:</b>	0.1 dB/°C
<b>Temperature Coefficient of 1 dBc:</b>	0.045 dB/°C
<b>Random Vibration:</b>	5.2 G(rms) 50 to 2000 Hz per Mil-Std-883C method 2026 test condition IIA
<b>Shock:</b>	1500 G (peak), 0.5 ms per Mil-Std-883C method 2002.3 test condition B
<b>Altitude (non-operating):</b>	15,000 m per Mil-Std-883C method 1001 test condition C
<b>EMC:</b>	Radiated Interference is within the requirements of VDE 0871 and CISPR Publication 11

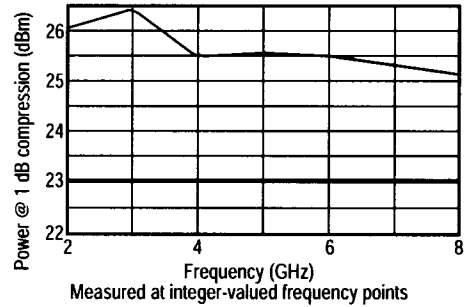

**Figure 4. Power Output vs. Frequency**

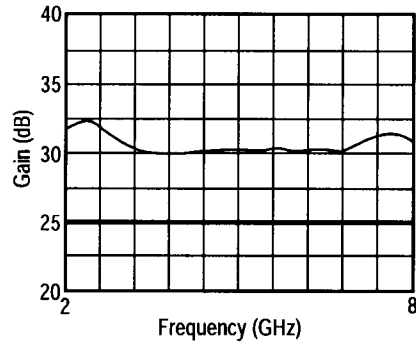

**Figure 5. Gain vs. Frequency**

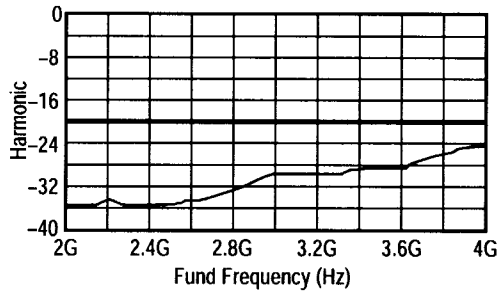

**Figure 6. Harmonics vs. Frequency**

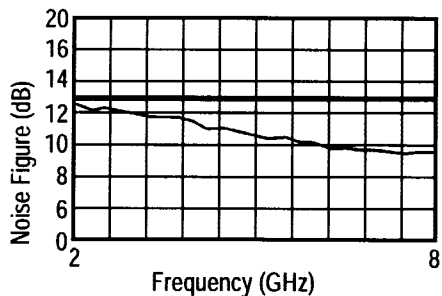

**Figure 7. Noise Figure vs. Frequency**

## Ordering Information

### 87415A Microwave System Amplifier

Includes amplifier and Agilent part number 83006-60004, which is a two meter cable with a 3-pin connector on one end and three wire leads on the other end.

### 87400A Microwave Amplifier

Microcircuit-only version of 87415A for OEM applications

## Other Instruments and Accessories

### 87421A Power Supply

Includes power supply and Agilent part number 83006-60005, which is a two meter cable with a 3-pin connector on one end and a D-subminiature connector on the other end.

### 87300B Coaxial Directional Coupler

### 8471E 0.01 to 12 GHz Coaxial Detector

### 83006-60004 dc Bias Cable

For use with user supplied power; consists of a two meter long shielded cable with a three pin connector on one end and three wire leads on the other end. Included with the 87415A microwave system amplifier.

### 83006-60005 dc Bias Cable

For use with 87421A power supply; consists of a two meter long shielded cable with a 3-pin connector on one end and a D-subminiature connector on the other end. Included with the 87421A power supply.

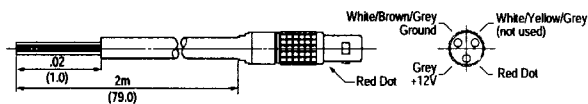

**Figure 8. 83006-60004 DC Bias Cable.**  
Dimensions in meters and (inches).